

JBCS J. Buckhill Consultancy Services

- Consulting Engineers
- Project Managers including Construction Management

SME Business Profile

IPA PNG BN: 6-123370



Dr. Jack B Khallahle MIEAust



Member of Engineers Australia since 2008
Member No: 3360870

J. Buckhill Consultancy Services
PO Box 3381, Lae
Morobe Province 411,
Papua New Guinea.

Website: www.jbuckhill.com
E-mail 1: info@jbuckhill.com
E-mail 2: jack@jbuckhill.com
E-mail 3: jack.khallahle@pnguot.ac.pg

J. BUCKHILL CONSULTANCY SERVICES (JBCS)

This is a SME business profile of J. Buckhill Consultancy Services, a nationally owned Consulting Engineering and Project Management firm based in Lae city. As a Small to Medium Enterprise (SME), JBCS is dedicated to provide professional engineering services in civil, mechanical, electrical engineering and project management services including construction management in Lae and throughout PNG. Below show images of two recent projects where JBCS Principal Dr Khallahle had involved in Lae for Trukai Industries and Broken Hill in Australia for Crystal Mining Ltd.

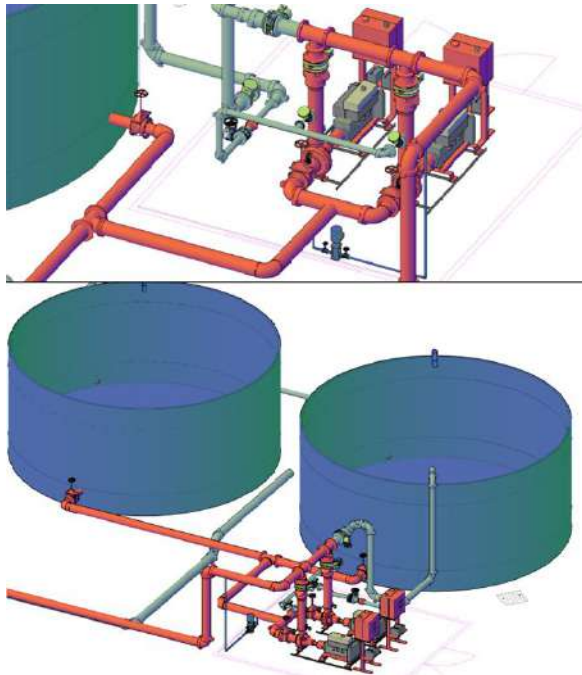

Fire Water Storage Tank, Trukai Industries PNG, Lae, 2015, PNG



Mineral Sand Separation Plant Project Completed in 2013, Broken Hill, NSW, Australia

Table of Contents

1. PHOTO GALLERY OF A CRITICAL PROJECT COMPLETION	3
2. PROFILE	4
3. VISION STATEMENT	5
4. MISSION STATEMENT	5
5. PRINCIPAL ENGINEER/MANAGER - CAREER OVERVIEW	6
6. PROJECT DELIVERY PROCESS.....	7
6. 1 Proposed Project Delivery Model for Clients Projects	7
7. MAJOR PROJECTS.....	9
8. ENGINEERING SERVICES	12
9. PROJECT DELIVERY SERVICES	12
10. STANDARD AND CONTRACT SPECIFICATIONS	13
10.1 Mine Infrastructure Project	13
10.2 Material Handling	13
10.3 Power Generation	13
10.4 Hydrocarbons	13
10.5 Water	14
10.6 Building Services - HVAC	14
11. PHOTO GALLERY	15
12. DESIGN GALLERY	24
13. HSE POLICY	27
14. ENVIRONMENTAL POLICY.....	28
15. QUALITY POLICY	29
16. HUMAN RESOURCES / EMPLOYEE RELATIONS POLICY	30
17. DRUG AND ALCOHOL POLICY	31
18. WHERE WE ARE LOCATED?	32
19. HOW TO CONTACT US.....	33



1. PHOTO GALLERY OF A CRITICAL PROJECT COMPLETION



Paraburdoo Train Load-out Conveyor 25 (CV25) – New Hybrid Take-up System. Designed, Procured and Implemented During a Three Days Maintenance Shut Down at Paraburdoo Mine in 2007 in Western Australia.

2. PROFILE

J. Buckhill Consultancy Services or "JBCS" in short are consulting engineers and project managers. We provide quality engineering and project management solutions from concept design to practical completion and project close out. JBCS provides expertise in Minerals and Metals, Hydrocarbons, Power, Infrastructure, Environment, Water and Building Services Engineering. We provide EPCM and PMC services that is capable of coping with the stringent demands of the resources, energy and manufacturing sectors.

JBCS engaged reputable civil, structural, mechanical and electrical engineers, project managers and sub-consultants. Together with this team of professionals and other respectable industry representatives, JBCS has forged a proven record of excellence in the engineering, procurement and construction management (EPCM) and Project Management Consultancy or Contracting (PMC) services from large projects through to small studies.

Currently, JBCS is paving the way with its new generation of environmentally friendly engineering solutions as core part of its business. JBCS is continually developing high-level design and specifications, project management process and construction methods to lead the industry to new levels of quality and innovation.

The major focus for JBCS is to develop eco-friendly designs and engineering solutions that limit impact on the environment while remaining cost-effective and of the highest quality and in full compliance with statutory requirements, codes and standards.

We are currently operating out of Lae and throughout PNG on a fly in/fly out basis from Lae city, PNG.

A detail **Technical Proposal** for engineering and project delivery services highlighting our technical capabilities and experiences can be submitted for your consideration if required.

For more information about our services, contact J. Buckhill Consultancy Services on mobile +675 70482895.



3. VISION STATEMENT

The Vision of J. Buckhill Consultancy Services is to be the preferred provider of Engineering and Project Management solution for all sectors and for all clients delivering timely and quality services to our Clients and Stakeholders.

4. MISSION STATEMENT

The mission of J. Buckhill Consultancy Services in achieving its Vision of becoming the provider of choice in engineering and project management solutions are encompassed in the following key business objectives.

- To provide an environment for our employees, sub-consultants, contractors and clients where our attention to Safety is a top priority at all our projects sites and paramount to success.
- To provide a timely and quality standard of service, that surpasses any industry competitors and genuinely delights our clients.
- To promote a working culture of openness, accountability, honesty, trust, respect and integrity in all of our business associations.
- To provide a platform where all employees can grow with the business in developing their skills, experiences and aim higher in order to achieve international standards and recognition and benefiting from the vast amount of key management expertise.
- To deliver above average returns to all of our clients and stakeholders.



5. PRINCIPAL ENGINEER/MANAGER - CAREER OVERVIEW



Dr. Jack B Khallahle MIEAust

PhD *USYD*, MEngSc *UNSW*, BEng *PNGUOT*, CPL (fixed Wing)
Principal Engineer/Manager/ Academic

Dr. Jack B Khallahle is the Principal Engineer and Manager of J. Buckhill Consultancy Services. Dr Khallahle has over 20 years of professional experience in engineering, procurement and construction management (EPCM) and project management consultancy or Contracting (PMC) services with consulting engineering and mining companies throughout Australia and PNG as a professional engineer working on both greenfield and brownfield capital projects. Dr Khallahle is highly experienced and versatile with diverse skills and fully knowledgeable in the design and implementation of civil, mechanical engineering, mine Infrastructure and continuous improvement projects or growth projects for existing mines and manufacturing plants.

Dr Khallahle has a Bachelor of Engineering (BEng) degree in mechanical engineering from the PNG University of Technology in 1987 and a Master of Engineering Science (MEngSc) degree in Mechanical Engineering from the University of New South Wales (UNSW) in Sydney Australia in 2001. Dr Khallahle is currently a Corporate Member of the Institution of Engineers Australia (MIEAust) with Chartered Professional Engineer (CPEng) membership application in progress.



Dr Khallahle is a multidiscipline Project Manager with proven records of good mentoring and people management skills. He once managed a *multi-national* project team as a Team Leader Engineering with Ok Tedi Mining Limited in PNG prior to working for Rio Tinto's Pilbara Iron, WorleyParsons Services and Parsons Brinckerhoff in Australia. Dr Khallahle is also a University Lecturer in mechanical engineering at PNG University of Technology, PNG.



6. PROJECT DELIVERY PROCESS

Irrespective of the nature of the work, JBCS offers a robust project delivery process, supported by proven project and quality management systems and procedures. This process ensures consistency of delivery across the complete service offering and can incorporate a gated approvals process as might be required for the Clients and its operations as illustrated in the diagram below.

The following schematic offers a high level summary of our project delivery process, highlighting the key components for a typical major capital works and gated approval process.

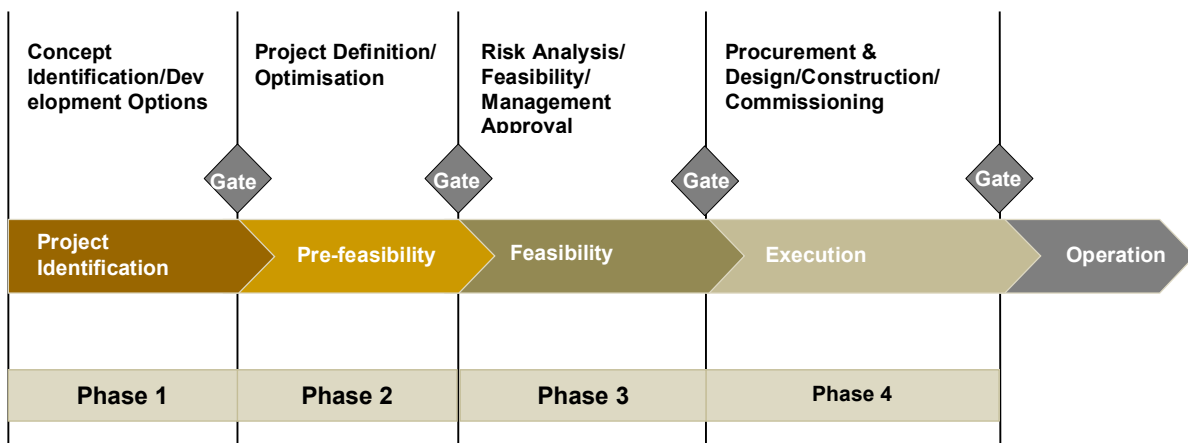

6. 1 Proposed Project Delivery Model for Clients Projects

The following proposal is intended for use throughout the Client project duration and intended to provide:

- An efficient means of project execution;
- The ability for the project team to respond to site requirements;
- The ability for the project definition and capital approval to occur as project develop;
- The ability to immediately start the project through the use of counterpart funds;

It is proposed that for Clients projects if undertaken by J. Buckhill Consultancy Services shall work directly with the stakeholders on site in support role during both design and implementation phase. The JBCS project team has been setup to specifically execute and part take in the private and resource sector infrastructure projects to provide quality project delivery services to existing infrastructure and also new projects.

A two-phase approach has been proposed for the execution of Clients projects as detailed below.

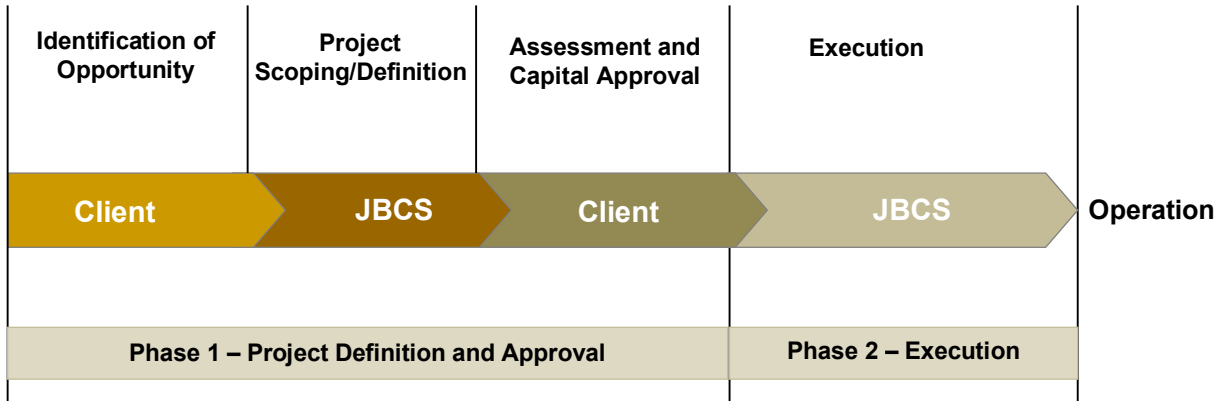

The two phase approach recognizes that Clients continually generates ideas and opportunities for the project during the design process in Phase 1. These opportunities are not necessarily to structural planning period and can arise at any time. Clients may wish to pursue these opportunities as they arise to take advantage of any potential economic benefits driving the project. Details on how model works are explained in our technical proposal to be submitted if required by Client.





7. MAJOR PROJECTS

The Principal and founder Dr Khallahle has completed many major projects at various sites throughout Australia and PNG as a project leader or project manager from concept design to practical implementation and commissioning. Dr Khallahle also conducted successful pre-feasibility and feasibility studies.

The following major projects have been completed meeting clients' requirements:

- **Mineral Sand Separation Plant Project**
Parsons Brinckerhoff for Bemax Resources Ltd, Broken Hill, NSW.
Capital cost, approximately \$29,000,000.
Design, Construction & Commissioned



- **10,000 Tonne Acid Storage Tank, Pump & Pipelines Replacement**
WorleyParsons Services for Nyrstar WorleyParsons Project Alliance, Port Pirie, SA. Capital cost approximately \$1,500,000.
Design, Construction & Commissioned

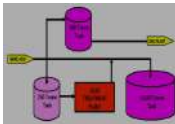

- **Neutral A Cooling Tower Refurbishment Project**
WorleyParsons Services for Nyrstar WorleyParsons Project Alliance, Port Pirie, SA. Capital cost approximately \$1,500,000
Design, Construction & Commissioned

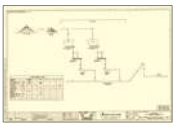

- **Mercury Removal Plant for the Sulphuric Acid Plant**
WorleyParsons Services for Nyrstar WorleyParsons Project Alliance, Port Pirie, SA. Capital cost, approximately \$4,500,000
Feasibility study

- **Coal Mill Baghouse Insulation Project**
WorleyParsons Services for Nyrstar WorleyParsons Project Alliance, Port Pirie, SA. Capital cost approximately \$450,000
Design, construction & Commissioned

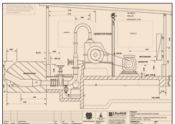

- **Coal Feed System using Bottom Bin Feed Screw Conveyors**
WorleyParsons Services for Nyrstar WorleyParsons Project Alliance, Port Pirie, SA. Capital cost approximately \$2,900,000
Pre-feasibility study



- **250 kW Karimui Mini Hydropower Scheme-Pre feasibility study**
Department of Simbu, Kundiawa, PNG
Approximately \$2,500,000
Pre-feasibility study

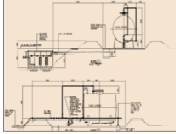

- **120 Person Karara Exploration Camp**
WorleyParsons Services for Gindalbie Metals, Perth, WA
Approximately \$3,000,000
Designed, Construction & Commissioned



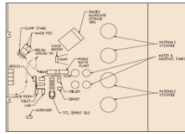

- **Construction Fuel Supply, Storage, Distribution Facility**
WorleyParsons Services for Gindalbie Metals, Perth, WA
Approximately \$2,000,000
Designed, Construction & Commissioned



- **Mobile Concrete Batch Plant for Karara Iron Ore Project**
WorleyParsons Services for Gindalbie Metals, Perth, WA
Approximately \$13,000,000
Designed, Construction & Commissioned



- **Paraburdoo CV25 Train Load-out Take-up System modification**
RIO Tinto, Pilbara Iron, Paraburdoo, WA
Approximately \$860,000
Designed, Construction & Commissioned



- **Paraburdoo CV604/555 Transfer Station Silt Trap & Slurry Pumps**
RIO Tinto, Pilbara Iron, Paraburdoo, WA
Approximately \$400,000
Designed, Construction & Commissioned

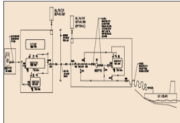

- **2.2 Km Eastern Range Mine Excess Road for Light Vehicle**
RIO Tinto, Pilbara Iron, Paraburdoo, WA
Approximately \$2,300,000
Designed, Construction & Commissioned



- **Paraburdoo Gas Turbine Fuel Line Transfer Project**
RIO Tinto, Pilbara Iron, Paraburdoo, WA
Approximately \$770,000
Designed, Construction & Commissioned

- **Bige-West Bank Fuel Distribution Facility for Dredging Operation**
Ok Tedi Mining Limited, Bige, PNG
Approximately \$360,000
Designed, Construction & Commissioned

- **Mill/ Mine Process and Potable Supply and Treatment Water Plant**
Ok Tedi Mining Limited, Mine Site, PNG
Approximately \$2,000,000
Designed, Construction & Commissioned

- **Tabubil Thermal Power Plant Water, Sediment Separation System**
Ok Tedi Mining Limited, Tabubil, PNG
Approximately \$250,000
Designed, Construction & Commissioned

- **13 kW Tari Micro Hydropower Scheme**
PlacerDome (Barrick Gold)-Porgera Joint Venture (PJV), Tari, PNG
Approximately \$250,000
Pre-feasibility Study



▪ **Elcom Haus Hohola – Air-conditioning & Mechanical Services**

PNG ELCOM, Port Moresby, PNG
Approximately \$150,000
Designed, Construction & Commissioned



▪ **Port Moresby General Hospital–A/C & Mechanical Services**

Department of Works, 3 Mile-Port Moresby, PNG
Capital cost of project approximately \$500, 000
Designed, Construction & Commissioned



▪ **Credit Corporation Building– A/C & Mechanical Services Design**

Credit Corporation of PNG, Port Moresby CBD, PNG
Approximately \$800, 000
Designed, Construction & Commissioned



8. ENGINEERING SERVICES

J. Buckhill Consultancy Services has substantial experience in providing the following services to Consulting Engineering and Mining Companies;

- Engineering, Procurement and Construction Management (EPCM) services
- Project Management Consultancy/Contracting (PMC) services
- Project Alliance services

J. Buckhill Consultancy Services provides the above services to the following areas to the Resource, Energy and Manufacturing Sectors;

- Minerals and Metals
- Hydrocarbons
- Power Generation
- Mine Infrastructure Projects
- Public Infrastructure Projects
- Environment and Water Engineering
- Building Services Engineering (HVAC)

9. PROJECT DELIVERY SERVICES

As specialists in project and program delivery we help clients achieve successful project outcomes through our experience in planning, design, procurement and construction.

Our project management services include:

- project management including construction management;
- project delivery and reporting;
- contract negotiation and administration;
- project controls;
- schedule management;
- cost estimating, engineering and capital cost monitoring;
- procurement;
- risk management;

Detail description of our project management services shall be submitted as part of the technical proposal if required.



10. STANDARD AND CONTRACT SPECIFICATIONS

The list below indicates JBCS capabilities and what we are able to design and deliver for our clients. The list under each heading are standard and contract specifications that the Principal of JBCS had developed for various greenfield and brownfield capital projects in the resource and energy sectors throughout Australia and various sites in PNG. JBCS provides complete engineering design, layout design and drawings using latest AutoCAD interlock with CAD for 3D modelling and animation. We develop very detail contract specifications and scope of works to tender and construction stage to suit client's specific project requirements for implementation at all sites:

10.1 Mine Infrastructure Project

- Earthworks; Storm Water Drainage; Concrete Supply; Structural Concrete
- Mobile Concrete Batch Plant
- Exploration and Construction Camp & Permanent Camp or Village
- Site services Design
- Roads, Bridges, Wharfs and Jetties Design & Project Management
- Mechanical Services including HVAC System design
- Fuel Supply, Storage and Distribution Facilities
- Hydrocarbon (Oil/Water) Separation Facilities
- Fabrication and Erection of Structural Steel & Metal Work for Buildings
- Water Reticulations and Fuel Supply Lines & Bulk Fuel Storage Facility

10.2 Material Handling

- Drive Assemblies; Belt Conveyor Pulleys; Ball and Roller Bearing Plummer Block; Belt Conveyor Idlers; Belt Conveyors; Belt Drives; Mechanical and Fluid Couplings; Conveyor Belting; Hydraulic Equipment; Bucket Elevators; Installation and Commissioning of Mechanical Equipment specification
- Primary Crusher; Secondary Crusher and Apron Feeders Specification
- Slurry and Sump Pumps Specification
- Conveyor Weightometers; Magnetic Separators and Vibrating Screen Specification and Transfer Chute

10.3 Power Generation

- Mini and Micro Hydropower Generation Scheme Design
- Thermal Power Plants (Gas Turbine & Gen set)
- Hired Gen Set Power Supply & Maintenance Contract for Camps

10.4 Hydrocarbons

- Fabrication & Installation of Welded and Threaded Piping for Hydrocarbon Services Specification
- Compressor and Pump Selection and Station Design
- Pipeline Design and Vales Selection
- Two Phase Flow in Gas/Liquid pipeline flow for on shore Pipeline Installation

10.5 Water

- Water Pumps Technical Specification
- Pipeline Engineering Design and Valves Selection
- Tailings Pipeline Design, Valves Selection and Pump Station Design
- Solar Powered Borefield Water Supply System for Rural PNG

10.6 Building Services - HVAC

- Air Conditioning Equipment Technical Specification
- Cooling and Heat Load Estimation and Duct Work Design
- Ventilation, Extraction System & Noise Control (Acoustics)
- Building hydraulics and Fire Protection Services System Design



11. PHOTO GALLERY

Mineral Sand Separation Plant Project for Cristal Mining Limited, Broken Hill, NSW, Australia, 2013.

Dr Khallahle was tasked as Construction Manager / Senior Project Engineer responsible for Site Mobilisation and Construction of the new Plant and also developed all Project Plans including Project Execution Plan, Building Certification and Approval process including Fire Safety Engineering System whilst on a one contract with Parsons Brinckerhoff in Adelaide, South Australia, 2013.



Paraburdoo Gas Turbine Diesel Fuel Line Transfer Project for Rio Tinto's Pilbara Iron, Paraburdoo, WA, Australia, 2006.



2.2 Km (Kilometre) Light Vehicle Mine Access Road – Eastern Range Mine, for Rio Tinto’s Pilbara Iron, Paraburdoo, WA, Australia.



Greater Paraburadoo CV25 Train Load-Out Facility-Take-up System Modification work,
Paraburadoo, Civil & Foundation Works for Rio Tinto, WA, Australia.



Greater Paraburadoo CV25 Train Load-Out Facility-Take-up System Modification work, Paraburadoo, Mechanical & Structural Installation Works for Rio Tinto, WA, Australia.



Paraburdoo CV604/CV555 Transfer Station Wash-down Pad, Silt Trap & Slurry Pumps Design and Installation for Rio Tinto, Paraburdoo Plant Site, WA, Australia.



120 Person Karara Exploration/Construction Camp-Karara Iron Ore Project for WorleyParsons/Gindalbie Metals, Karara Site-Ihouz & Kitchen Installation, WA, Australia.



120 Person Karara Exploration/Construction Camp-Karara Iron Ore Project for WorleyParsons/Gindalbie Metals, Karara Site- Sewage, Power Supply Installation & finally Landscaping, WA, Australia.



13 kW Paijaka Micro Hydropower Scheme pre-Feasibility Study, Tari, Hela Province for Barrick Gold (Porgera Joint Venture), PNG.

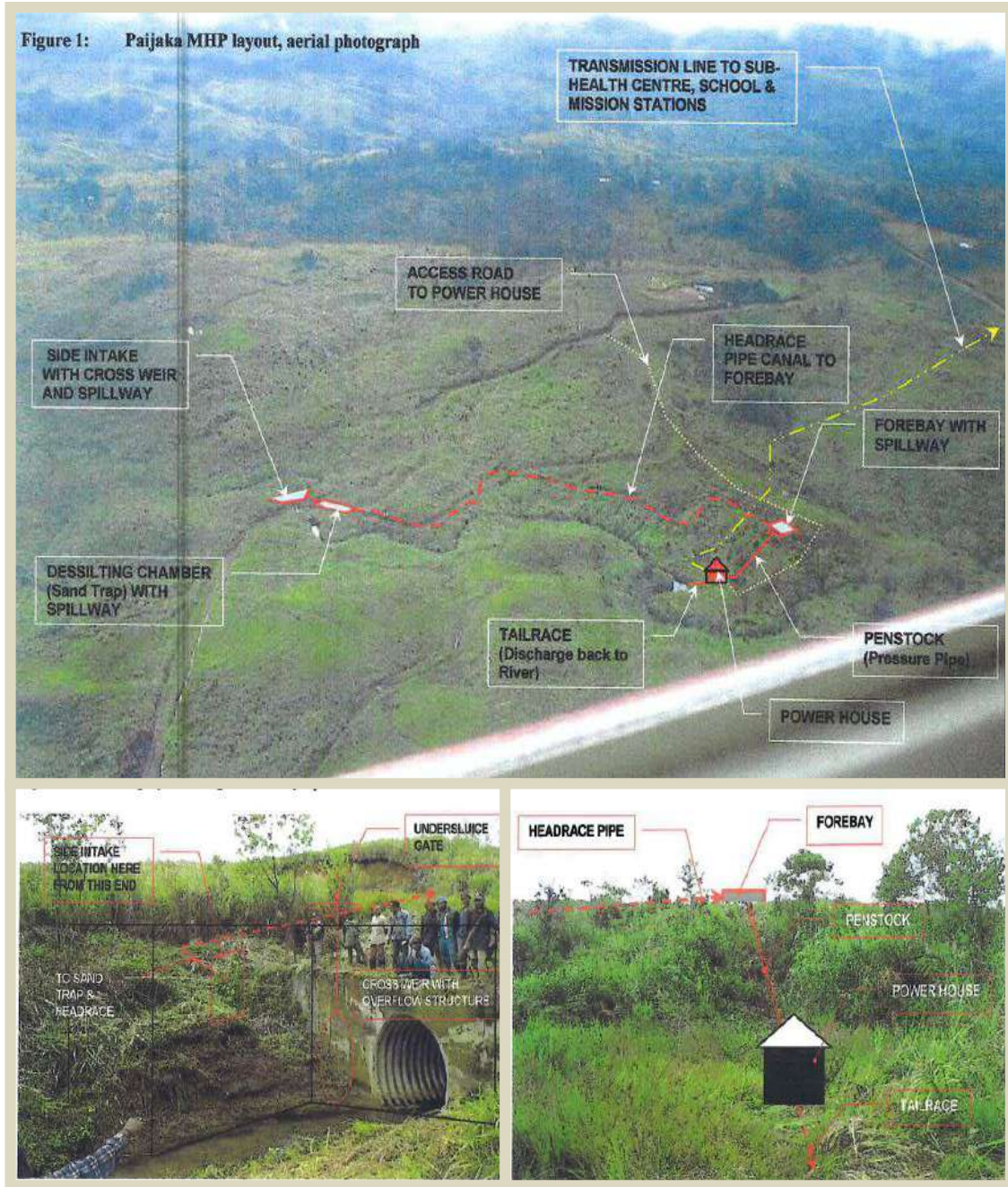

12. DESIGN GALLERY

13kW Pajaka Micro Hydropower Scheme Design for pre-Feasibility Study, Tari, Hela Province for Barrick Gold (Porgera Joint Venture), PNG.

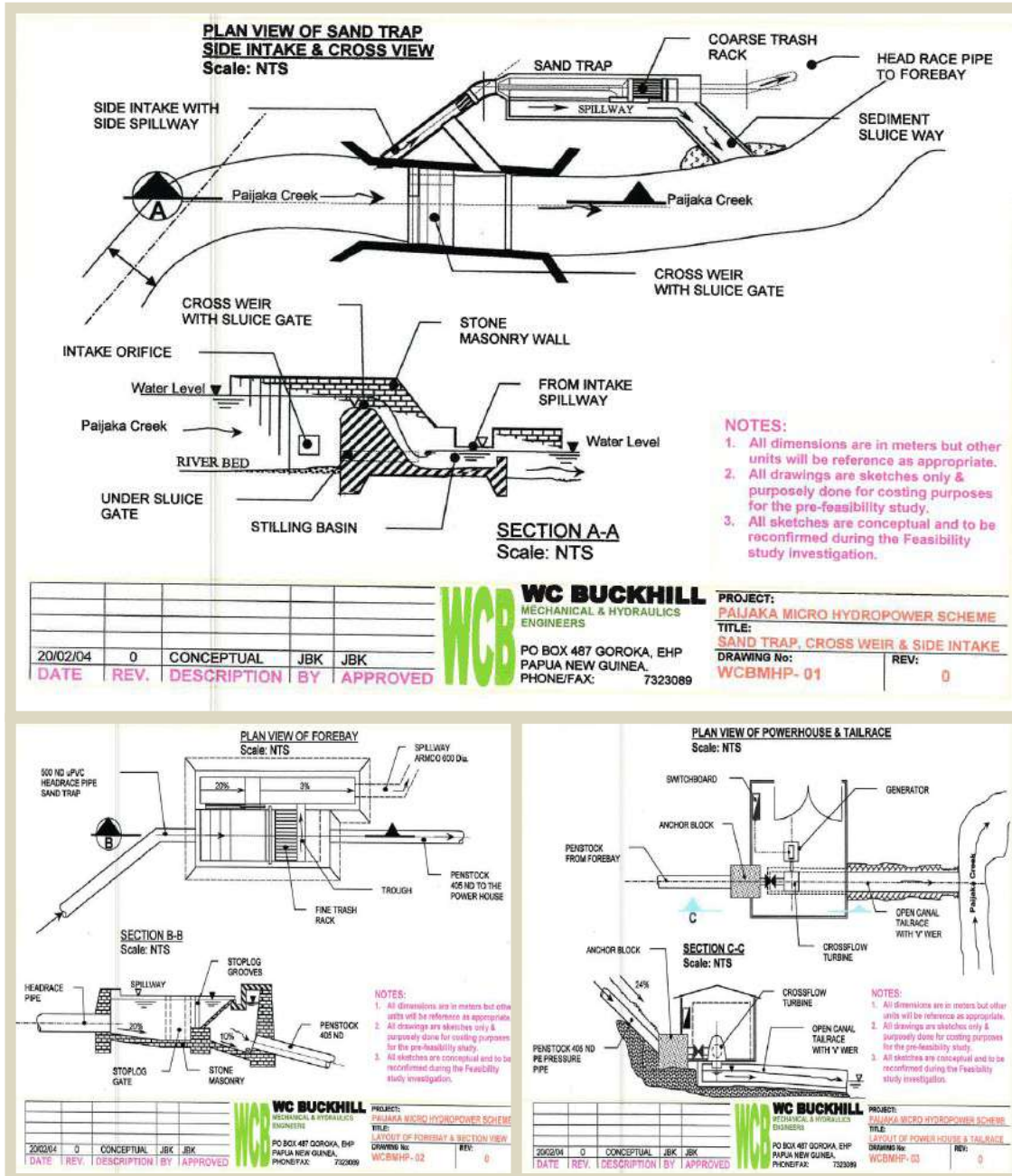

Paraburdoo Train Load-out Conveyor 25 (CV25) Take-Up System Layout Design for
Modification Work for Rio Tinto's Pilbara Iron, WA

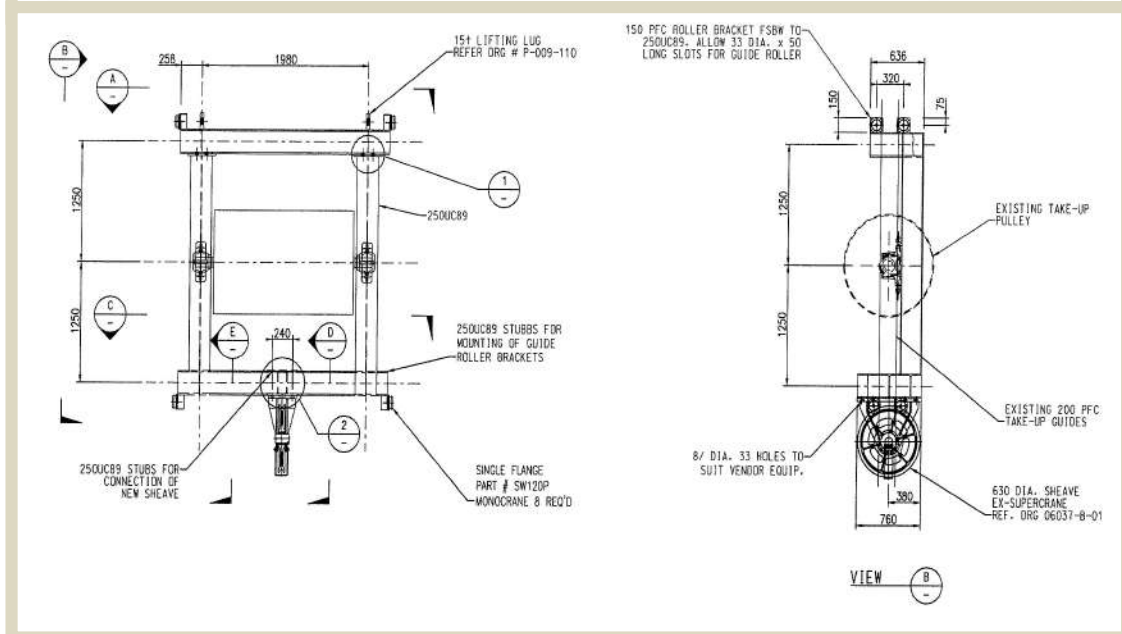
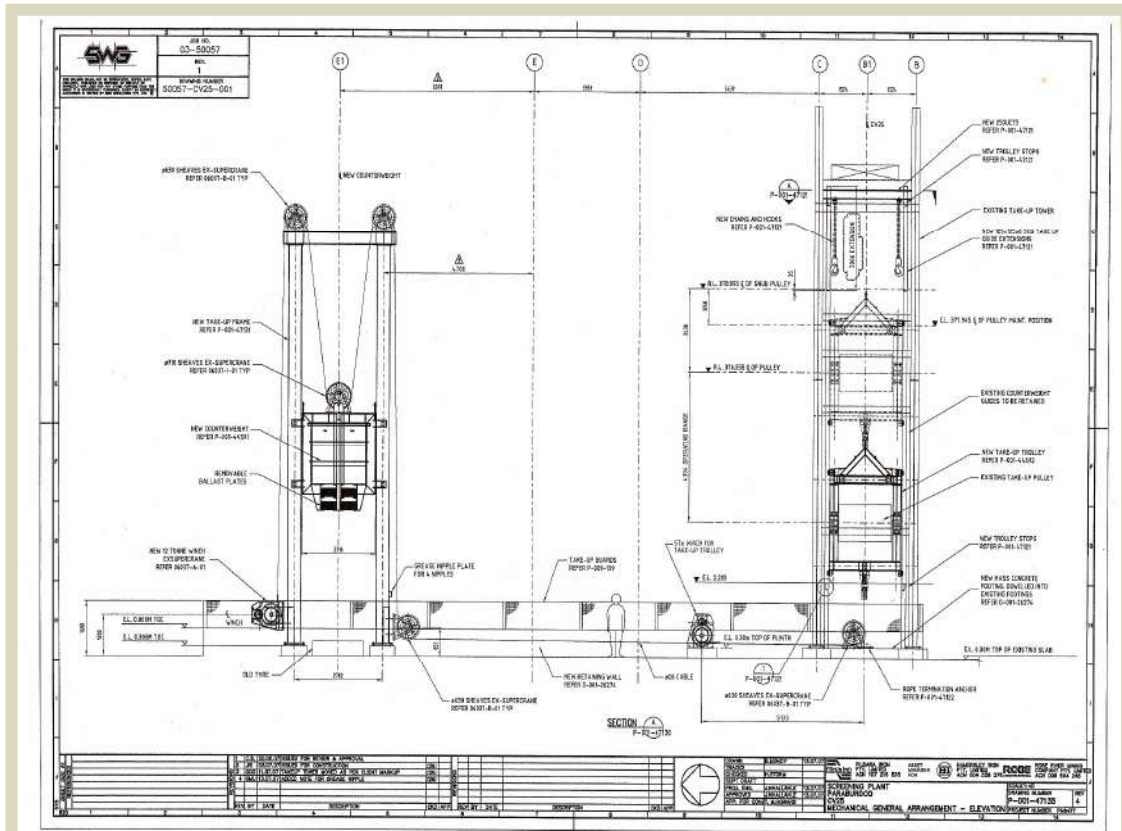

13. HSE POLICY

This policy recognises that the work health, safety and environment, (HSE) of all employees and contractors working under the supervision of J. Buckhill Consultancy Services are the responsibility of JBCS Management team. In fulfilling this responsibility, JBCS has a duty to provide and maintain, so far as is practicable, a working environment that is safe and without risk to health and as good corporate citizens it shall provide and promote environmental policies, which demonstrate its commitment to protecting the environment.

This responsibility includes:

- Making sure that Contractors provide and maintain safe plant and systems of work at all our construction site;
- Making sure that Contractors monitor and arrange for the safe use, handling, storage and transport of plant and substances;
- Making sure that Contractors workplace is maintained in a safe and healthy condition; and
- Providing information, training and supervision for all employees enabling them to work in a safe, environmentally conscientious manner.
- JBCS is committed to ensuring that its environmental, health and safety policy meets with all of the relevant regulatory, heritage and legislative requirements and through its policy of continual improvement it will endeavour to improve its performance, particularly in the prevention of pollution and workplace accidents/incidents.

The environment, health and safety management at all levels will be detailed and JBCS procedures for training and back-up support will be followed. In fulfilling the objectives of this policy, JBCS is committed to regular consultation with employees to ensure that the policy operates effectively, and that environment, health and safety issues are regularly reviewed.

Dr. Jack Khallahle MIEAust
Principal Engineer
18 November 2023



14. ENVIRONMENTAL POLICY

J. Buckhill Consultancy Services recognises that protection of the environment is an extremely important aspect within its business operations and a necessary element of good corporate citizenship.

JBCS is committed to implementing systems and procedures to facilitate the adoption and maintenance of sound environmental management and operating practices and to ensure the continual improvement of environmental performance on all sites it operates.

JBCS Environmental Management System will operate to maintain a formalised method of control and minimise the environmental impact of all of its activities and the activities of the Contractors. JBCS environmental objectives are:

- To exceed the level of environmental performance required for regulatory compliance on all projects
- To establish and maintain environmentally responsible waste management and waste disposal practices on all projects sites
- To improve the efficiency of energy use
- To minimise harm to flora and fauna
- To store all materials in a manner that reduces their potential release to the atmosphere, soil or water
- To reduce the potential for environmental harm in emergency situations by responding effectively to any emergency using trained personnel and formalised emergency plans on all sites
- To ensure that contractors and suppliers conform to relevant requirements of our Environmental Policy
- To promote the adoption of sound environmental practices by all personnel through the improvement of overall environmental awareness

JBCS will provide the resources required for achieving effective environmental management, and by so doing give both the client and the community an assurance of their sound environmental performance.

Dr. Jack Khallahle MIEAust
Principal Engineer
18 November 2023



15. QUALITY POLICY

J. Buckhill Consultancy Services is committed to the principles of Quality Assurance in the operation of our business on a day to day basis. This commitment to Quality and the philosophy of Continuous Improvement is seen as the collective responsibility of all employees, sub-consultants, Contractors and Sub-contractors.

The aim of JBCS Quality Policy is to achieve:

- Excellence in Client Service.
- Design concepts that meet all of our client's requirements.
- Fit for purpose engineering solutions and outcomes.
- Clearly defined work practices, systems and procedures.
- A Continuous Improvement program that enhances our business.
- Maintain and Improve the Standard of our final outcome delivered to our clients.

The goal of JBCS is to be recognised as the engineer of choice to our clients through the provision of value for money solutions and services.

Dr. Jack Khallahle MIEAust
Principal Engineer
18 November 2023



16. HUMAN RESOURCES / EMPLOYEE RELATIONS POLICY

This policy recognises that the work environment, Employee Relations / HR of all employees both on Contract and full time employee working with J. Buckhill Consultancy Services are the responsibility of JBCS management team.

In fulfilling this responsibility, management has a duty to provide and maintain, so far as is practicable, a working environment that meets all statutory requirements, is safe and without risk to health for its employees and the employee of our Contractors working on our clients' projects.

This responsibility includes but is not limited to:

- Making sure that Contractors provide and maintain safe plant and systems of work.
- Conducting regular, formal Toolbox meetings with Contractors.
- Maintaining the workplace in a safe and healthy condition; and
- Structured reviews and appraisals of employee performance with detailed support systems as required.
- Providing information, training and supervision for all employees enabling them to work in a safe, environmentally conscientious manner while in the office and on site.

JBCS is committed to ensuring that its Employee Relations / HR duties policy meets with all of the relevant regulatory legislative requirements and through its policy of continual improvement it will endeavour to improve its performance, particularly in the areas of:

- The Employee Relations / HR duties of management at all levels will be detailed and JBCS procedures for training and back-up support will be followed.

In fulfilling the objectives of this policy, management is committed to regular consultation with employees to ensure that the policy operates effectively, and that Employee Relations / HR issues are regularly reviewed.

Dr. Jack Khallahle MIEAust
Principal Engineer
18 November 2023



17. DRUG AND ALCOHOL POLICY

J. Buckhill Consultancy Services is committed in providing a safe and healthy working environment for all employees, contractors and visitors by eliminating hazards associated with the inappropriate use of alcohol and other drugs. This responsibility is shared by, employees, contractors and subcontractors. Inappropriate use of drugs and/or alcohol by employees or other persons at JBCS workplaces, site offices, project sites and contractor's site office can adversely affect work performance and is a contributing factor to workplace incidents and injuries. JBCS values their employees and employees of its contractors and believes that early intervention in the area of drug and alcohol dependency can motivate employees to deal with a situation, which may otherwise jeopardise workplace safety and their employment. JBCS is committed to:

- Ensuring all employees, contractors, subcontractors and visitors to the site are informed of the policy, their responsibilities and the consequences of policy breaches;
- Providing education and training in the hazards associated with alcohol and drugs, including prescribed medications, over the counter medication and drugs of abuse in the workplace;
- Providing employees with confidential counselling and assistance to prevent and manage inappropriate use of alcohol and drugs and the associated problems;
- Applying an appropriate testing and screening program to all employees, contractors, subcontractors and visitors;
- Maintaining effective procedures for managing alcohol and other drug issues and applying procedures fairly and in a manner consistent with this policy. Employees, contractors, subcontractors and visitors shall:
 - Agree not to attend work/site under the influence of alcohol, drugs or any other performance impairing substance;
 - If they are affected by drugs or alcohol they will not be allowed to work/enter the site until they can do so in a safe manner;
 - Assessment of the ability of a person to work in a safe manner will be made by site supervisor.
 - Where applicable employees, contractors, subcontractors and visitors shall abide by the 'Drug and Alcohol Policies and Procedures' which apply for particular projects on which they are engaged.
 - Agree to undergo substance abuse or breath analyse testing at any time while on client site. Drugs to be tested include: marijuana, barbiturates, benzodiazepines, amphetamines, cocaine, opiates, methadone and alcohol. If detected with any of these substances in their system, they shall be forbidden entrance to the workplace and in the case of employees may be summarily dismissed.

Dr. Jack Khallahle MIEAust
Principal Engineer
18 November 2023

18. WHERE WE ARE LOCATED?



19. HOW TO CONTACT US

OFFICE LOCATION & CONTACT

LAE

J. Buckhill Consultancy Services
Oxford Drive 153, Unitech,
PO Box 3381, Lae, Morobe Province,
Papua New Guinea.

Mobile: +675 70482895

Email: info@jbuckhill.com; jack@jbuckhill.com

Website: www.jbuckhill.com

